



GT34C02A

Advanced

GT34C02A

2K Bits

SPD EEPROM

Copyright © 2010 Giantec Semiconductor Inc. (Giantec). All rights reserved. Giantec reserves the right to make changes to this specification and its products at any time without notice. Giantec products are not designed, intended, authorized or warranted for use as components in systems or equipment intended for critical medical or surgical equipment, aerospace or military, or other applications planned to support or sustain life. It is the customer's obligation to optimize the design in their own products for the best performance and optimization on the functionality and etc. Giantec assumes no liability arising out of the application or use of any information, products or services described herein. Customers are advised to obtain the latest version of this device specification before relying on any published information and prior placing orders for products.



GT34C02A

Table of Contents

1. Features	3
2. General Description	3
3. Functional Block Diagram	4
4. Pin Configuration	5
4.1 8-Pin SOIC/SOP and TSSOP	5
4.2 8-Lead UDFN	5
4.3 Pin Definition	5
4.4 Pin Descriptions	5
5. Device Operation	6
5.1 2-WIRE Bus	6
5.2 The Bus Protocol	6
5.3 Start Condition	6
5.4 Stop Condition	6
5.5 Acknowledge	6
5.6 Reset	6
5.7 Standby Mode	6
5.8 Device Addressing	6
5.9 Write Operation	7
5.10 Read Operation	7
5.11 Write Protection	8
5.12. Diagrams	11
6. Electrical Characteristics	15
6.1 Absolute Maximum Ratings	15
6.2 Operating Range	15
6.3 Capacitance	15
6.4 DC Electrical Characteristic	16
6.5 AC Electrical Characteristic	17
7. Ordering Information	18
8. Top Markings	19
8.1 UDFN Package	19
8.2 TSSOP Package	19
8.3 SOIC/SOP Package	19
9. Package Information	20
9.1 UDFN	20
9.2 TSSOP	21
9.3 SOIC/SOP	22
10. Revision History	23



GT34C02A

1. Features

- Supply voltage: 1.7V to 5.5V
- 2-wire serial interface I²C compatible
- Speed up to 1000 KHz
- Organization:
 - 256 X 8-bit
- Low operating current
 - Standby Current less than 1 μ A (1.7V)
 - Standby Current less than 3 μ A (5.5V)
 - Active Current less than 3 mA (5.5V)
- Byte and Page (up to 16 bytes) Write Operations
 - Partial Page-writes permitted
- Random and Sequential Read modes
- Self-Time Write Cycle (5ms, max)
- Data Protection Features
 - Write Protect Pin
 - Permanent Software Protection
 - Reversible Software Protection
- Filtered Inputs for Noise Suppression
- More than 1 million Erase/Write Endurance Cycles
- More than 100 years Data Retention
- Packages: UDFN, TSSOP and SOIC/SOP
- Operating Temperature range: -40°C to +85°C

2. General Description

The GT34C02A is a 2K-bit Serial Presence Detect (SPD) EEPROM, which is fully compatible to industrial standard I²C interface. The GT34C02A contains a memory array of 2K bits (256x8), which is organized in 16-byte per page.

The GT34C02A product operates from 1.7V to 5.5V to satisfy the voltage requirements of DDR3, DDR2, and many other specifications. The device is offered in Lead-free, RoHS, halogen free or Green package. The available package types are 8-pin UDFN, TSSOP and SOIC/SOP.

The GT34C02A have two data protection features. One of the features is to permanently lock the data in its first half (lower) 128 bytes (address 00h to 7Fh). This feature is specifically designed for use in DRAM DIMM with SPD. All information concerning the DRAM module configuration (e.g. access speed, size, and organization) can be kept write-protected in the first half of the memory. The second half (upper) 128 bytes of the memory (address 80h to FFh) can't be write-protected using two different software write protection mechanisms. By sending a specified sequence to the device, the first 128 bytes memory can be

write-protected either permanently or reversible. The operating temperature ranging is from -40°C to +85°C.

In order to refrain the state machine entering into a wrong state during power-up sequence or a power toggle off-on condition, a power on reset circuit is embedded. During power-up, the device does not respond to any instructions until the supply voltage (V_{CC}) has reached an acceptable stable level above the reset threshold voltage. Once V_{CC} passes the power on reset threshold, the device is reset and enters into the Standby mode. This would also avoid any inadvertent Write operations during power-up stage. During power-down process, the device will enter into standby mode, once V_{CC} drops below the power on reset threshold voltage. In addition, the device will be in standby mode after receiving the Stop command, provided that no internal write operation is in progress. Nevertheless, it is not recommended to send a command until the V_{CC} reaches its operating level.



GT34C02A

3. Functional Block Diagram

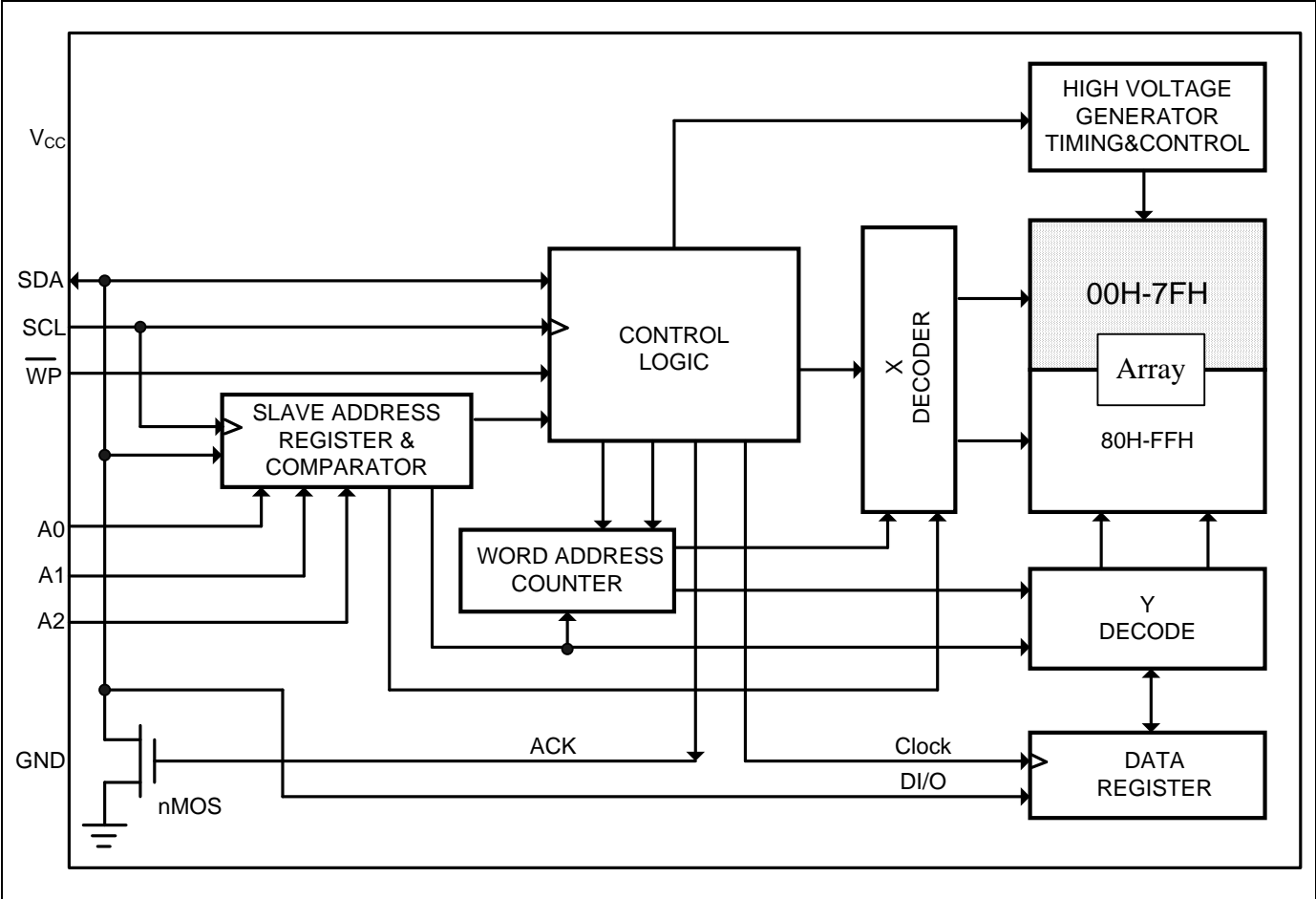



GT34C02A

4. Pin Configuration

4.1 8-Pin SOIC/SOP and TSSOP

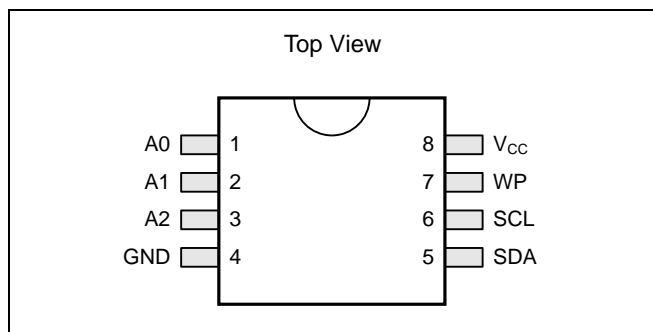

4.2 8-Lead UDFN

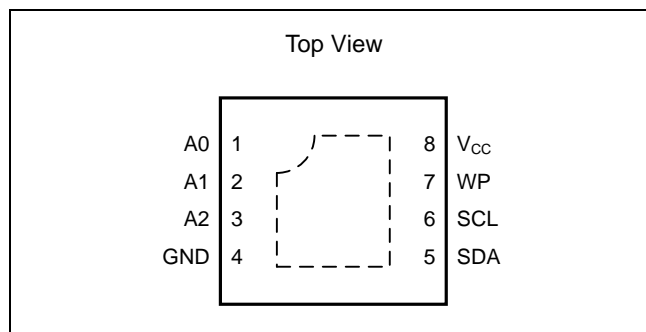

4.3 Pin Definition

Pin No.	Pin Name	I/O	Definition
1	A0	I	Device Address Input
2	A1	I	Device Address Input
3	A2	I	Device Address Input
4	GND	-	Ground
5	SDA	I/O	Serial Address, Data input and Data output
6	SCL	I	Serial Clock Input
7	WP	I	Write Protect Input
8	V _{cc}	-	Power Supply

4.4 Pin Descriptions

SCL

This input clock pin is used to synchronize the data transfer to and from the device.

SDA

The SDA is a bi-directional pin used to transfer addresses and data into and out of the device. The SDA pin is an open drain output and can be wired with other open drain or open collector outputs. However, the SDA pin requires a pull-up resistor connected to the power supply.

A0, A1, A2

The A0, A1 and A2 are the device address inputs.

Typically, the A0, A1, and A2 pins are for hardware addressing and a total of 8 devices can be connected on a single bus system. When A0, A1, and A2 are left floating,

the inputs are defaulted to zero.

WP

WP is the Write Protect pin. While the WP pin is connected to the power supply of GT34C02A, the entire array becomes Write Protected (i.e. the device becomes Read only). When WP is tied to Ground or left floating, the normal write operations are allowed. If the device has already received a write-protection command, the memory in the range of 00h-7Fh is read-on regardless of the setting of the WP pin.

V_{cc}

Supply voltage

GND

Ground of supply voltage



GT34C02A

5. Device Operation

The GT34C02A serial interface supports communications using industrial standard 2-wire bus protocol, such as I²C.

5.1 2-WIRE Bus

The GT34C02A utilizes the industrial standard 2-wire bus supporting I²C protocol to communicate with a master controller. The master generates the SCL signal and the GT34C02A being a slave device utilizes the SCL signal to receive or send data via the SDA line. Data transfer is serial, bi-directional, and is one bit at a time with the Most Significant Bit (MSB) transferred first, and a complete I²C bus data is 1-byte. Since SDA is open-drain, pull-up resistor is required.

5.2 The Bus Protocol

- Data transfer may be initiated only when the bus is not busy
- During a data transfer, the SDA line must remain stable whenever the SCL line is high. Any changes in the SDA line while the SCL line is high will be interpreted as a Start or Stop condition.

The state of the SDA line represents valid data after a Start condition. The SDA line must be stable for the duration of the High period of the clock signal. The data on the SDA line may be changed during the low period of the clock signal. There is one clock pulse per bit of data. Each data transfer is initiated with a Start condition and terminated with a Stop condition.

5.3 Start Condition

The Start condition precedes all commands to the device and is defined as a High to Low transition of SDA when SCL is High. The EEPROM monitors the SDA and SCL lines and will not respond until the Start condition is met.

5.4 Stop Condition

The Stop condition is defined as a Low to High transition of SDA when SCL is High. All operations must end with a Stop condition.

5.5 Acknowledge

After a successful data transfer, each receiving device is required to generate an ACK. The Acknowledging device pulls down the SDA line.

5.6 Reset

The GT34C02A contains a reset function in case the 2-wire bus transmission on is accidentally interrupted (e.g. a power loss), or needs to be terminated mid-stream. The reset is initiated when the Master device creates a Start condition. To do this, it may be necessary for the Master device to monitor the SDA line while cycling the SCL up to nine times. (For each clock signal transition to High, the Master checks for a High level on SDA.)

5.7 Standby Mode

While in standby mode, the power consumption is minimal. The GT34C02A enters into standby mode during one of the following conditions: a) After Power-up, while no Op-code is sent; b) After the completion of an operation and followed by the Stop signal, provided that the previous operation is not Write related; or c) After the completion of any internal write operations.

5.8 Device Addressing

The Master begins a transmission on by sending a Start condition, and then sends the address of the particular Slave devices to be communicated. The Slave device address is 8 bits format as shown in Table 5-1.

The four most significant bits of the Slave address are fixed (1010) for normal read/write operation, and 0110 for permanent write-protection operation.

The next three bits, A0, A1 and A2, of the Slave address are specifically related to EEPROM. Up to eight GT34C02A units can be connected to the 2-wire bus.

The last bit of the Slave address specifies whether a Read or Write operation is to be performed. When this bit is set to 1, Read operation is selected. While it is set to 0, Write operation is selected.

After the Master transmits the Start condition and Slave address byte appropriately, the associated 2-wire Slave device, GT34C02A, will respond with ACK on the SDA line. Then GT34C02A will pull down the SDA on the ninth clock cycle, signaling that it received the eight bits of data.



GT34C02A

Table 5.1 Device Address Format

Memory Area Function	Slave Address							R/ \bar{W} #
	Device Type Identifier				Select Address Signals			
	D3	D2	D1	D0	A2	A1	A0	
Read/Write EEPROM memory	1	0	1	0	A2	A1	A0	R/ \bar{W} #
Set Write Protection (SWP)	0	1	1	0	0	0	1	0
Clear Write Protection (CWP)					0	1	1	0
Permanently Set Write Protection (PSWP)					A2	A1	A0	0
Read SWP					0	0	1	1
Read CWP					0	1	1	1
Read PSWP					A2	A1	A0	1

Note: D3 (MSB), R/ \bar{W} # (LSB)

5.9 Write Operation

5.9.1 Byte Write

In the Byte Write mode, the Master device sends the Start condition and the Slave address information (with the R/ \bar{W} set to Zero) to the Slave device. After the Slave generates an ACK, the Master sends the byte address that is to be written into the address pointer of the GT34C02A. After receiving another ACK from the Slave, the Master device transmits the data byte to be written into the address memory location. The GT34C02A acknowledges once more and the Master generates the Stop condition, at which time the device begins its internal programming cycle. While this internal cycle is in progress, the device will not respond to any request from the Master device.

5.9.2 Page Write

The GT34C02A is capable of 16-byte Page-Write operation. A Page-Write is initiated in the same manner as a Byte Write, but instead of terminating the internal Write cycle after the first data word is transferred, the Master device can transmit up to 15 more bytes. After the receipt of each data word, the EEPROM responds immediately with an ACK on SDA line, and the four lower order data word address bits are internally incremented by one, while the higher order bits of the data word address remain constant.

If a byte address is incremented from the last byte of a page, it returns to the first byte of that page. If the Master device should transmit more than 16 bytes prior to issuing the Stop condition, the address counter will “roll over,” and the previously written data will be overwritten. Once all 16 bytes are received and the Stop condition has been sent by the Master, the internal programming cycle begins. At this point, all received data is written to the GT34C02A in a single Write cycle. All inputs are disabled until completion of the internal Write cycle.

5.9.3 Acknowledge Polling

The disabling of the inputs can be used to take advantage of the typical Write cycle time. Once the Stop condition is issued to indicate the end of the host's Write operation, the GT34C02A initiates the internal Write cycle. ACK polling can be initiated immediately. This involves issuing the Start condition followed by the Slave address for a Write operation. If the EEPROM is still busy with the Write operation, no ACK will be returned. If the GT34C02A has completed the Write operation, an ACK will be returned and the host can then proceed with the next Read or Write operation.

5.10 Read Operation

Read operations are initiated in the same manner as Write



GT34C02A

operations, except that the (R/\overline{W}) bit of the Slave address is set to "1". There are three Read operation options: current address read, random address read and sequential read.

5.10.1 Current Address Read

The GT34C02A contains an internal address counter which maintains the address of the last byte accessed, incremented by one. For example, if the previous operation is either a Read or Write operation addressed to the address location n , the internal address counter would increment to address location $n+1$. When the EEPROM receives the Slave Addressing Byte with a Read operation (R/\overline{W} bit set to "1"), it will respond an ACK and transmit the 8-bit data byte stored at address location $n+1$. The Master should not acknowledge the transfer but should generate a Stop condition so the GT34C02A discontinues transmission. If 'n' is the last byte of the memory, the data from location '0' will be transmitted. (Refer to Figure 5-8. Current Address Read Diagram.)

5.10.2 Random Address Read

Selective Read operations allow the Master device to select at random any memory location for a Read operation. The Master device first performs a 'dummy' Write operation by sending the Start condition, Slave address and byte address of the location it wishes to read. After the GT34C02A acknowledges the byte address, the Master device resends the Start condition and the Slave address, this time with the R/\overline{W} bit set to one. The EEPROM then responds with its ACK and sends the data requested. The Master device does not send an ACK but will generate a Stop condition. (Refer to Figure 5-9. Random Address Read Diagram.)

5.10.3 Sequential Read

Sequential Reads can be initiated as either a Current Address Read or Random Address Read. After the GT34C02A sends the initial byte sequence, the Master device now responds with an ACK indicating it requires additional data from the GT34C02A. The EEPROM continues to output data for each ACK received. The Master device terminates the sequential Read operation by pulling

SDA High (no ACK) indicating the last data word to be read, followed by a Stop condition. The data output is sequential, with the data from address n followed by the data from address $n+1, n+2 \dots$ etc.. The address counter increments by one automatically, and allows the entire memory contents to be serially read during sequential Read operation. When the memory address boundary of the array is reached, the address counter "rolls over" to address 0, and the device continues to output data. (Refer to Figure 5-10. Sequential Read Diagram).

5.11 Write Protection

5.11.1 Hardware Write Protection

The GT34C02A has two forms of software write protection and one form of hardware write protection. The hardware write protection is enabled when the WP input is held High. In this case, the entire array of the GT34C02A is read-only regardless of the status of the software protection. The hardware protection is disabled when the WP input is held Low or is floating. In this case, the upper half of the array (80h-FFh) can be modified by a valid Write command, and the lower half of the array (00h-7Fh) can be modified only if software write protection has not been enabled.

5.11.2 Reversible Software Write Protection

There is a non-volatile flag for each of the two forms of software write protection. When the bit value for either flag or both flags is 1, it is not possible to modify the contents of the lower 128 bytes of the array (00h-7Fh). If the bit value for both flags is 0, it is possible to modify this half of the array with a valid Write command, assuming WP is held Low or is floating. The device is shipped with both flags cleared. One of those flags is the Reversible Software Write Protection (RSWP) flag, and can be changed with the Set RSWP and Clear RSWP commands. The flag can also be verified without being changed with a Read SWP command. In order to set, clear or read the RSWP, The GT34C02A input pins must be as follows: A0 must be held to an extra high voltage of V_{HV} (see DC Characteristics), while A2 and A1 must be set High, Low, or left floating, depending on the desired command (see Figure 5-5). Once these input conditions are met, a command can be issued to the



GT34C02A

device.

The reversible software commands are initiated similarly to a normal byte write operation; however, the slave device address begins with the bit values 0110. The next three bits are A2=0, A1=0 or 1, and A0=1, so that they logically match the values on the input pins. If the last bit of the slave device address (R/\bar{W}) is 0, the RSWP flag can be Cleared or Set. If R/\bar{W} is 1, the flag can be verified with the Read SWP command. Following this bit, the device responds with either ACK or NoACK, depending on the exact command and the flag status (see Table 5.2: Reversible Instructions). To complete the Set RSWP or Clear RSWP command, the Master must transmit a dummy address byte, a dummy data byte, and a Stop signal. To actually modify the RSWP flag, WP should be held Low or be floating during entire command sequence. Before resuming any other command, the internal write cycle time should be observed. To complete the Read SWP Status or Read CWP Status command, the Master can transmit a Stop signal after the ACK/NoACK. The WP input is not evaluated for the Read SWP Status or Read CWP Status commands.

5.11.3 Permanent Software Write Protection

The GT34C02A contains a permanent software write protection (PSWP) feature. If the non-volatile PSWP flag has a bit value of 1, the array region of 00h-7Fh is protected from modification. If the PSWP flag has a bit value of 0, the write protection for the lower half of the array is determined solely by the statuses of RSWP and the WP input. After the PSWP flag is set to 1 via the Permanent Write Protect command, the protected area becomes irreversibly

read-only despite power removal and re-application on the device. Once enabled, the permanent protection is independent of the status of the WP pin.

The Permanent Software Write Protect command is initiated similarly to a normal byte write operation; however, the slave device address begins with the bit values of 0110 (see figure 5-5). The following three bits are A2-A0, so that they logically match the values on the input pins. The last bit of the slave address (R/\bar{W}) is 0. The GT34C02A responds with either ACK or NoACK, depending on the flag status (see Table 5.2: Permanent Instructions). Assuming an ACK is received, Master then must complete the sequence by transmitting a dummy address byte, dummy data byte, and a Stop signal (see Figure 5-11). The WP pin should be held Low or left floating during the entire command. Before resuming any other command, the internal write cycle should be observed.

The status of the PSWP can be safely determined without any changes by transmitting the same slave address as above, but with the last bit (R/\bar{W}) set to 1 (see Figure 5-12). If the PSWP has been set, the GT34C02A will not acknowledge any slave address starting with bits 0110 (see Table 5.2). To complete the command, the Master can transmit a Stop signal after the ACK/NoACK.



GT34C02A

Table 5.2 ACK Status

Normal Instructions									
Command	PSWP (Permanent)	RSWP (Reversible)	WP ^[1]	ACK command	Address	ACK Address	Data Byte	Data Byte ACK	Write Cycle
Read	X	X	X	ACK	00h-FFh	ACK	Data Byte	ACK	No
Write	0	0	0	ACK	00h-FFh	ACK	Data Byte	ACK	Yes
Write	X	X	1	ACK	00h-FFh	ACK	Data Byte	NoACK	No
Write	1	X	0	ACK	00h-7Fh	ACK	Data Byte	NoACK	No
Write	X	1	0	ACK	00h-7Fh	ACK	Data Byte	NoACK	No
Write	X	X	0	ACK	80h-FFh	ACK	Data Byte	ACK	Yes
Permanent Instructions									
Command	PSWP (Permanent)	RSWP (Reversible)	WP ^[1]	ACK command	Address	ACK Address	Data Byte	Data Byte ACK	Write Cycle
Read PSWP Status ^[4]	0	X	X	ACK	Dummy Address	NoACK	Dummy Byte	NoACK	No
Read PSWP Status	1	X	X	NoACK	-	-	-	-	No
Set PSWP	0	X	0	ACK	Dummy Address	ACK	Dummy Byte	ACK	Yes
Set PSWP	0	X	1	ACK	Dummy Address	ACK	Dummy Byte	NoACK	No
Set PSWP	1	X	X	NoACK	-	-	-	-	No
Reversible Instructions									
Command	PSWP (Permanent)	RSWP (Reversible)	WP ^[1]	ACK command	Address	ACK Address	Data Byte	Data Byte ACK	Write Cycle
Read SWP Status ^[4]	0	0	X	ACK	-	-	-	-	No
Read SWP Status	0	1	X	NoACK	-	-	-	-	No
Read SWP Status ^[4]	1	0	X	NoACK	-	-	-	-	No
Read SWP Status	1	1	X	NoACK	-	-	-	-	No
Read CWP status ^[3,4]	0	X	X	ACK	-	-	-	-	No
Read CWP status ^[3]	1	X	X	NoACK	-	-	-	-	No
Set RSWP	0	0	0	ACK	Dummy Address	ACK	Dummy Byte	ACK	Yes
Set RSWP	0	1	X	NoACK	-	-	-	-	No
Set RSWP	1	0	X	NoACK	-	-	-	-	No
Set RSWP	1	1	X	NoACK	-	-	-	-	No
Set RSWP	0	0	1	ACK	Dummy Address	ACK	Dummy Byte	NoACK	No
Clear RSWP	0	0	0	ACK	Dummy Address	ACK	Dummy Byte	ACK	Yes
Clear RSWP	1	0	X	NoACK	-	-	-	-	No
Clear RSWP	0	1	0	ACK	Dummy Address	ACK	Dummy Byte	ACK	Yes
Clear RSWP	1	1	X	NoACK	-	-	-	-	No
Clear RSWP	0	0	1	ACK	Dummy Address	ACK	Dummy Byte	NoACK	No
Clear RSWP	0	1	1	ACK	Dummy Address	ACK	Dummy Byte	NoACK	No

Note: ^[1]WP = 1 if input level is High. WP = 0 if input level is GND or floating

^[2]X = Don't care

^[3]Read CWP status yields the same result as Read PSWP Status

^[4]Read out Don't Care Dummy Address and Dummy Data is optional



GT34C02A

5.12. Diagrams

Figure 5-1. Typical System Bus Configuration

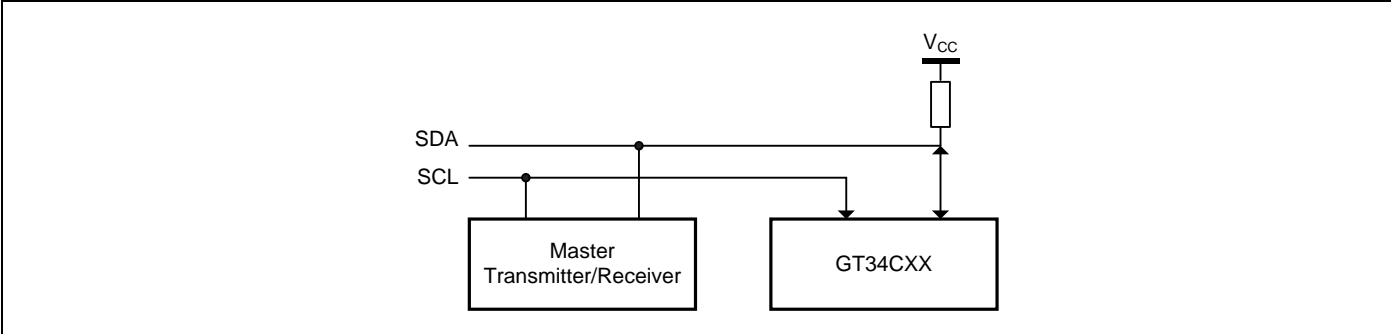

Figure 5-2. Output Acknowledge

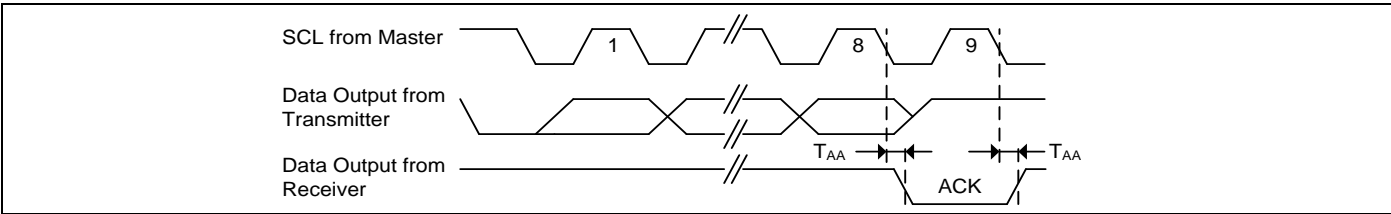

Figure 5-3. Start and Stop Conditions

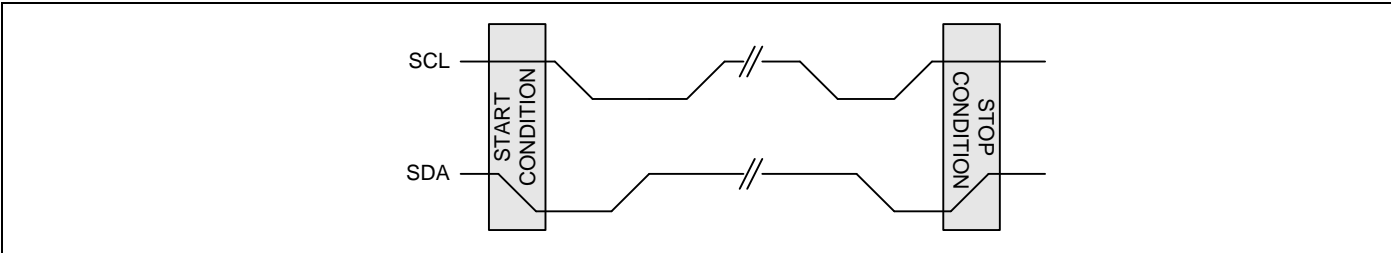
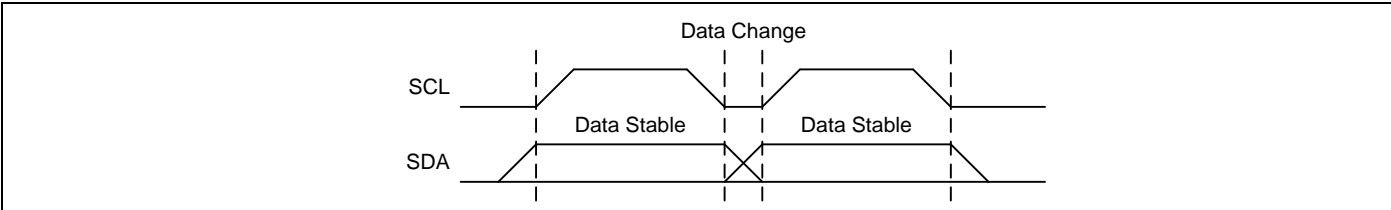

Figure 5-4. Data Validity Protocol





GT34C02A

Figure 5-5. Command Configuration

Pin Connection ^[1]			Slave Device Address									
A2	A1	A0	Bit	7	6	5	4	3	2	1	0	
A2	A1	A0		1	0	1	0	A2	A1	A0	R/W	Normal Instruction ^[2]
A2	A1	A0		0	1	1	0	A2	A1	A0	R/W	Permanent Write Protection Instruction ^[2]
GND	GND	V _{HV}		0	1	1	0	0	0	1	0	Set Write Protection (SWP)
GND	V _{CC}	V _{HV}		0	1	1	0	0	1	1	0	Clear Write Protection (CWP)
GND	GND	V _{HV}		0	1	1	0	0	0	1	1	Read SWP
GND	V _{CC}	V _{HV}		0	1	1	0	0	1	1	1	Read CWP

Notes:

^[1] A2-A0 input pin connections must be GND (or floating), V_{CC} or V_{HV}

^[2] Bits 1, 2 and 3 of the device address will be compared with the values on the external pins

Figure 5-6. Byte Write

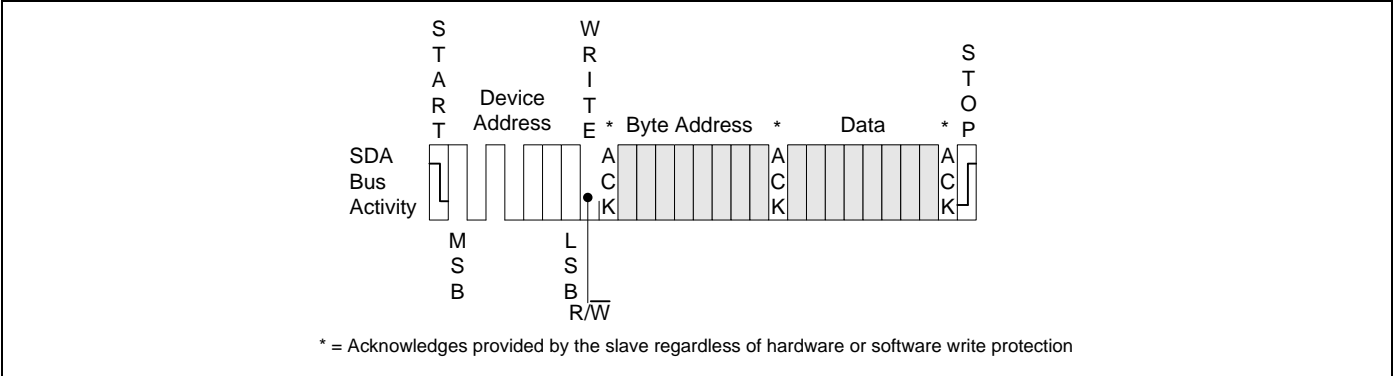
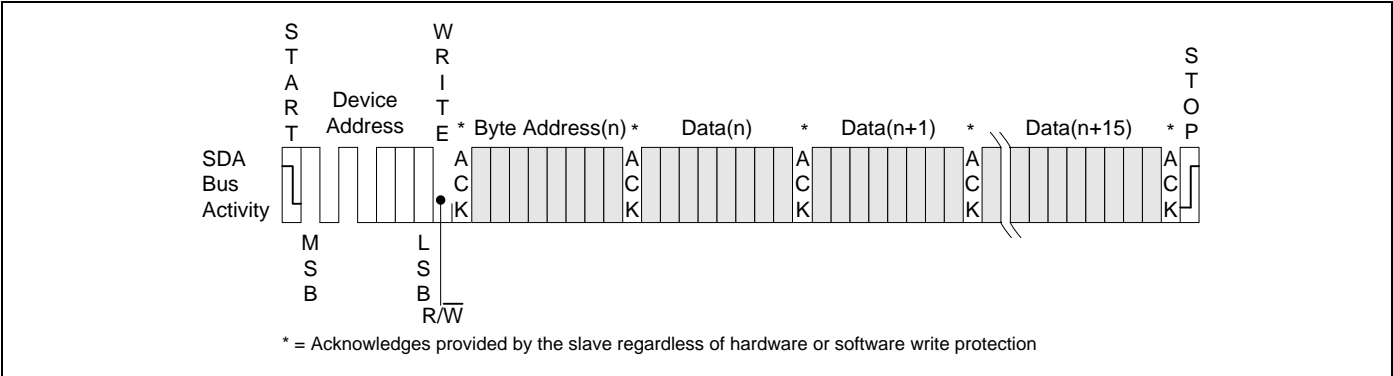

Figure 5-7. Page Write





GT34C02A

Figure 5-8. Current Address Read

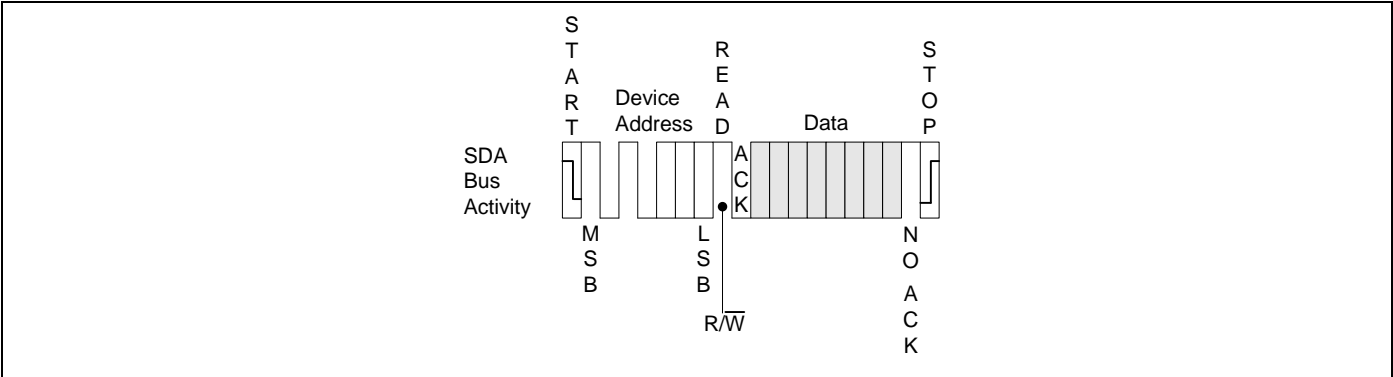

Figure 5-9. Random Address Read

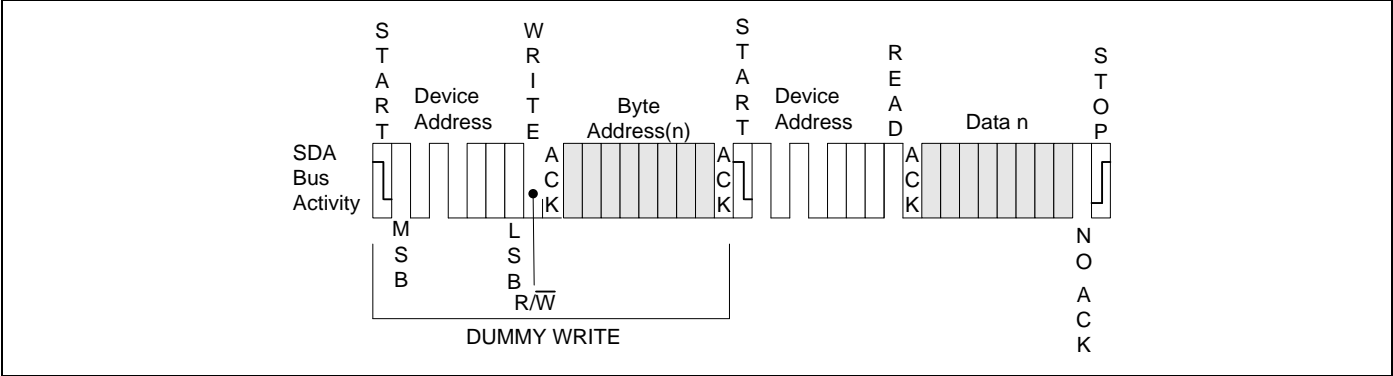

Figure 5-10. Sequential Read

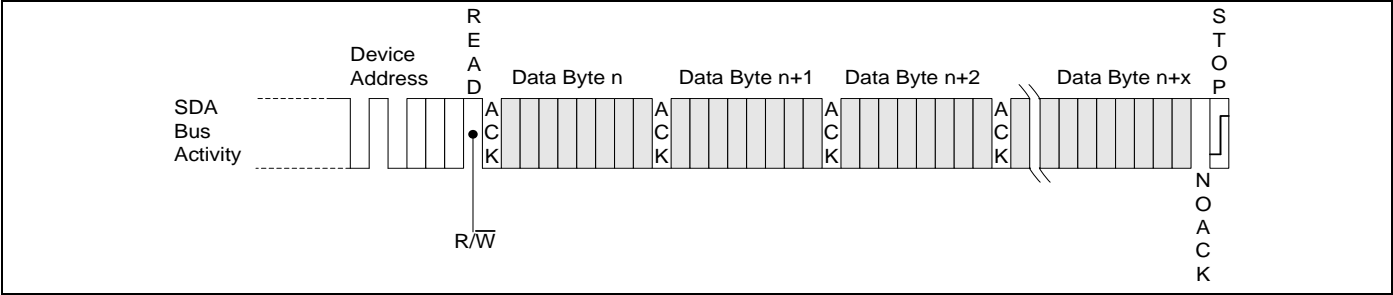

Figure 5-11. Set Permanent Write Protection

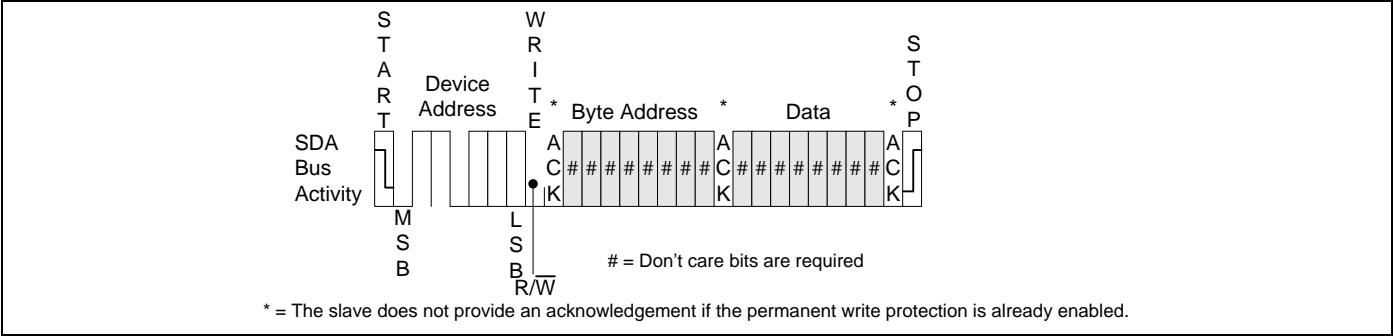



Figure 5-12. Read Permanent Write Protection

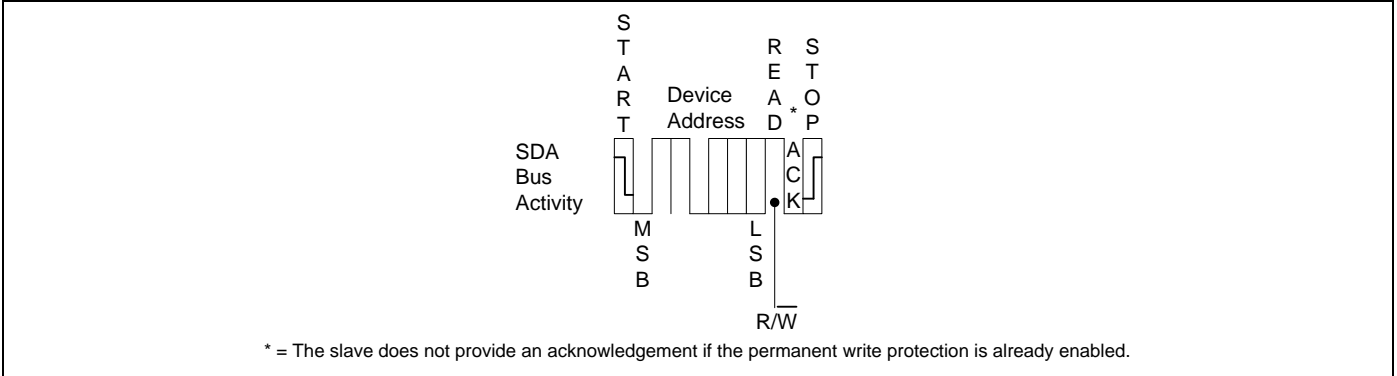

Figure 5-13. Bus Timing

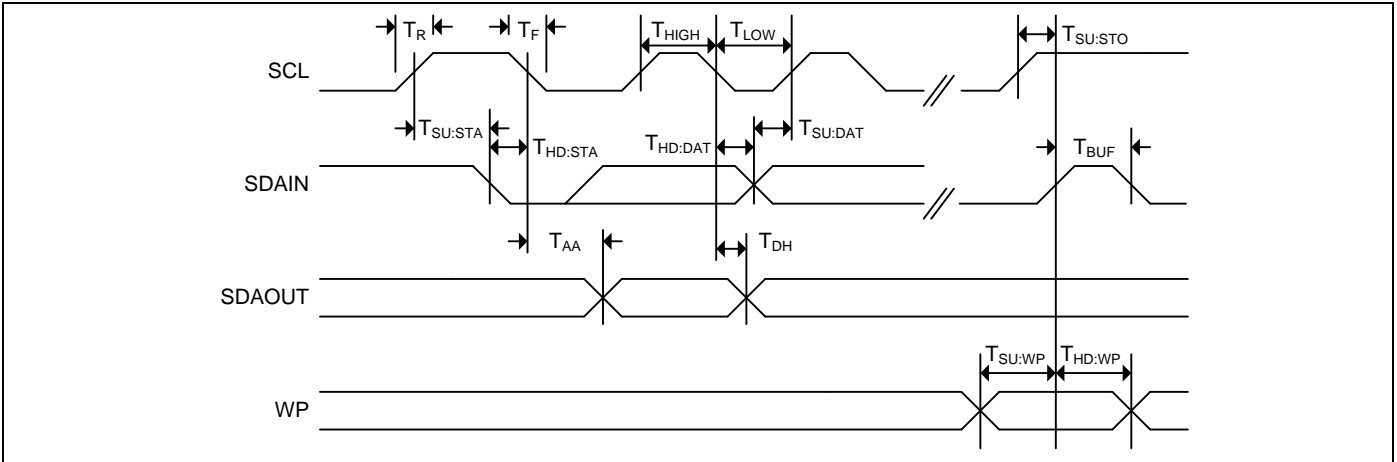
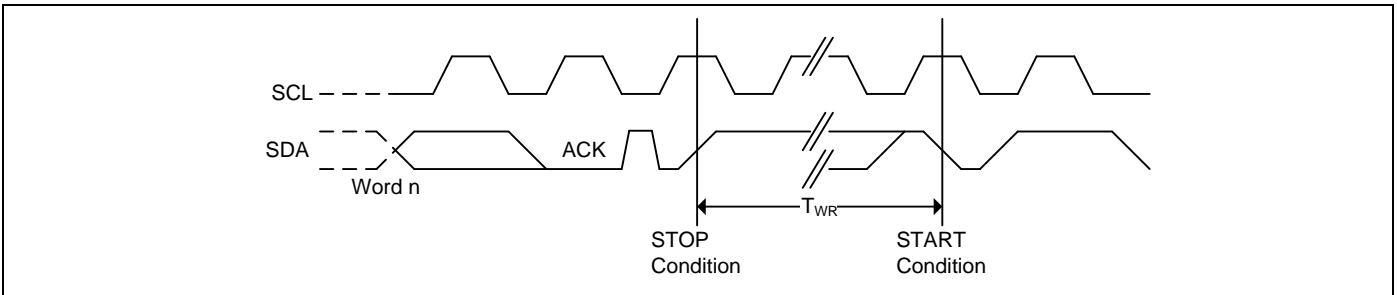

Figure 5-14. Write Cycle Timing





GT34C02A

6. Electrical Characteristics

6.1 Absolute Maximum Ratings

Symbol	Parameter	Value	Unit
V_S	Supply Voltage	-0.5 to +6.5	V
V_P	Voltage on Any Pin	-0.5 to $V_{CC} + 0.5$	V
T_{BIAS}	Temperature Under Bias	-55 to +125	°C
T_{STG}	Storage Temperature	-65 to +150	°C
I_{OUT}	Output Current	5	mA

Note: Stress greater than those listed under Absolute Maximum Ratings may cause permanent damage to the device. This is a stress rating only and functional operation of the device at these or any other condition outside those indicated in the operational sections of this specification is not implied. Exposure to absolute maximum rating conditions for extended periods may affect reliability.

6.2 Operating Range

Range	Ambient Temperature (T_A)	V_{CC}
Industrial	-40°C to +85°C	1.7V to 5.5V

Note: Giantec offers Industrial grade for Commercial applications (0°C to +70°C).

6.3 Capacitance

Symbol	Parameter ^[1, 2]	Conditions	Max.	Unit
C_{IN}	Input Capacitance	$V_{IN} = 0V$	6	pF
$C_{I/O}$	Input / Output Capacitance	$V_{I/O} = 0V$	8	pF

Notes: ^[1] Tested initially and after any design or process changes that may affect these parameters and not 100% tested.

^[2] Test conditions: $T_A = 25^\circ\text{C}$, $f = 1\text{ MHz}$, $V_{CC} = 2.7V$ to $3.6V$, unless otherwise specified.



GT34C02A

6.4 DC Electrical Characteristic

Industrial: $T_A = -40^{\circ}\text{C}$ to $+85^{\circ}\text{C}$, $V_{CC} = 1.7\text{V} \sim 5.5\text{V}$

Symbol	Parameter [1]	V _{CC}	Test Conditions	Min.	Max.	Unit
V _{CC}	Supply Voltage			1.7	5.5	V
V _{IH}	Input High Voltage			0.7*V _{CC}	V _{CC} +0.5	V
V _{IL}	Input Low Voltage			-1	0.3* V _{CC}	V
V _{HV}	A0 High Voltage		V _{HV} - V _{CC} ≥ 4.8V	7	10	V
I _{LI}	Input Leakage Current	5.5V	V _{IN} = V _{CC} or GND, standby mode	—	3	μA
I _{LO}	Output Leakage Current	5.5V	V _{OUT} = V _{CC} or GND, SDA in Hi-Z	—	3	μA
V _{OL1}	Output Low Voltage	1.7V	I _{OL} = 0.15 mA	—	0.2	V
V _{OL2}	Output Low Voltage	5.5V	I _{OL} = 2.1 mA	—	0.4	V
I _{SB}	Standby Current	1.7V	V _{IN} = V _{CC} or GND	—	1	μA
		3.6V	V _{IN} = V _{CC} or GND	—	2	μA
		5.5V	V _{IN} = V _{CC} or GND	—	3	μA
I _{CC1}	Read Current	1.7V	Read at 400 KHz	—	1	mA
		3.6V	Read at 1 MHz	—	2	mA
		5.5V	Read at 1 MHz	—	3	mA
I _{CC2}	Write Current	1.7V	Write at 400 KHz	—	1	mA
		3.6V	Write at 1 MHz	—	2	mA
		5.5V	Write at 1 MHz	—	3	mA

Note: [1] The parameters are characterized but not 100% tested.



GT34C02A

6.5 AC Electrical Characteristic

Industrial: $T_A = -40^{\circ}\text{C}$ to $+85^{\circ}\text{C}$, Supply voltage = 1.7V to 5.5V

Symbol	Parameter [1] [2]	1.7V \leq V _{CC} <2.5V		2.5V \leq V _{CC} <4.5V		4.5V \leq V _{CC} \leq 5.5V		Unit
		Min.	Max.	Min.	Max.	Min.	Max.	
F _{SCL}	SCK Clock Frequency		400		1000		1000	KHz
T _{LOW}	Clock Low Period	1300	—	600	—	600	—	ns
T _{HIGH}	Clock High Period	600	—	400	—	400	—	ns
T _R	Rise Time (SCL and SDA)	—	300	—	300	—	300	ns
T _F	Fall Time (SCL and SDA)	—	300	—	100	—	100	ns
T _{SU:STA}	Start Condition Setup Time	600	—	250	—	250	—	ns
T _{SU:STO}	Stop Condition Setup Time	600	—	250	—	250	—	ns
T _{HD:STA}	Start Condition Hold Time	600	—	250	—	250	—	ns
T _{HD:STO}	Stop Condition Hold Time	600	—	250	—	250	—	ns
T _{SU:DAT}	Data In Setup Time	100	—	100	—	100	—	ns
T _{HD:DAT}	Data In Hold Time	0	—	0	—	0	—	ns
T _{AA}	Clock to Output Access time (SCL Low to SDA Data Out Valid)	100	900	50	400	50	400	ns
T _{DH}	Data Out Hold Time (SCL Low to SDA Data Out Change)	100	—	50	—	50	—	ns
T _{WR}	Write Cycle Time	—	5	—	5	—	5	ms
T _{BUF}	Bus Free Time Before New Transmission	1300	—	600	—	600	—	ns
T _{SU:WP}	WP pin Setup Time	600	—	600	—	600	—	ns
T _{HD:WP}	WP pin Hold Time	600	—	600	—	600	—	ns
T	Noise Suppression Time	—	100	—	50	—	50	ns

Notes: [1] The parameters are characterized but not 100% tested.

[2] AC measurement conditions:

R_L (connects to V_{CC}): 1.3 k Ω (2.5V, 5.0V), 10 k Ω (1.7V)

C_L = 100 pF

Input pulse voltages: 0.3*V_{CC} to 0.7*V_{CC}

Input rise and fall times: \leq 50 ns

Timing reference voltages: half V_{CC} level



GT34C02A

7. Ordering Information

Industrial Grade: -40°C to +85°C, Lead-free

Voltage Range	Part Number*	Package (8-pin)*
1.7V to 5.5V	GT34C02A-2UDLI-TR	2 x 3 x 0.55 mm Ultra-thin DFN
	GT34C02A-2ZLI-TR	3 x 4.4 mm TSSOP
	GT34C02A-2GLI-TR	150-mil SOIC/SOP (JEDEC)

*

1. Contact Giantec Sales Representatives for availability and other package information.
2. The product is packed in tape and reel "-TR" (4K per reel), except UDFN is 5K per reel.
3. Refer to Giantec website for related declaration document on lead free, RoHS, halogen free or Green, whichever is applicable.
4. Giantec offers Industrial grade for Commercial applications (0°C to +70°C).



GT34C02A

8. Top Markings

8.1 UDFN Package



GT: Giantec Logo
61A: GT34C02A-2UDLI-TR
YWW: Date Code, Y=year, WW=week

8.2 TSSOP Package



GT: Giantec Logo
602A-2ZLI: GT34C02A-2ZLI-TR
YWW: Date Code, Y=year, WW=week

8.3 SOIC/SOP Package

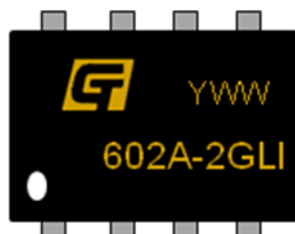

G: Giantec Logo
602A-2GLI: GT34C02A-2GLI-TR
YWW: Date Code, Y=year, WW=week



GT34C02A

9. Package Information

9.1 UDFN

8L 2x3mm UDFN Package Outline

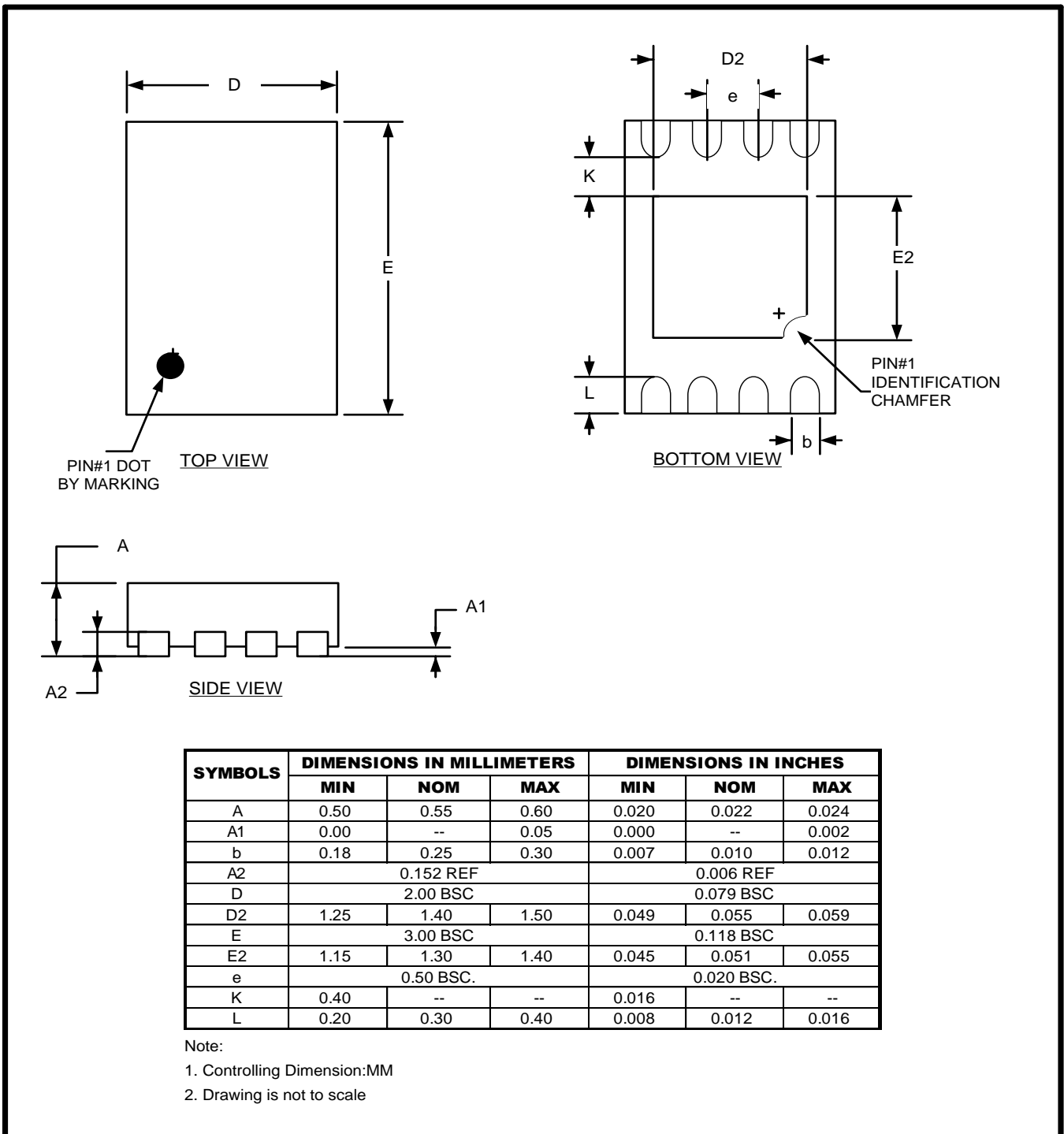



GT34C02A

9.2 TSSOP

8L 3x4.4mm TSSOP Package Outline

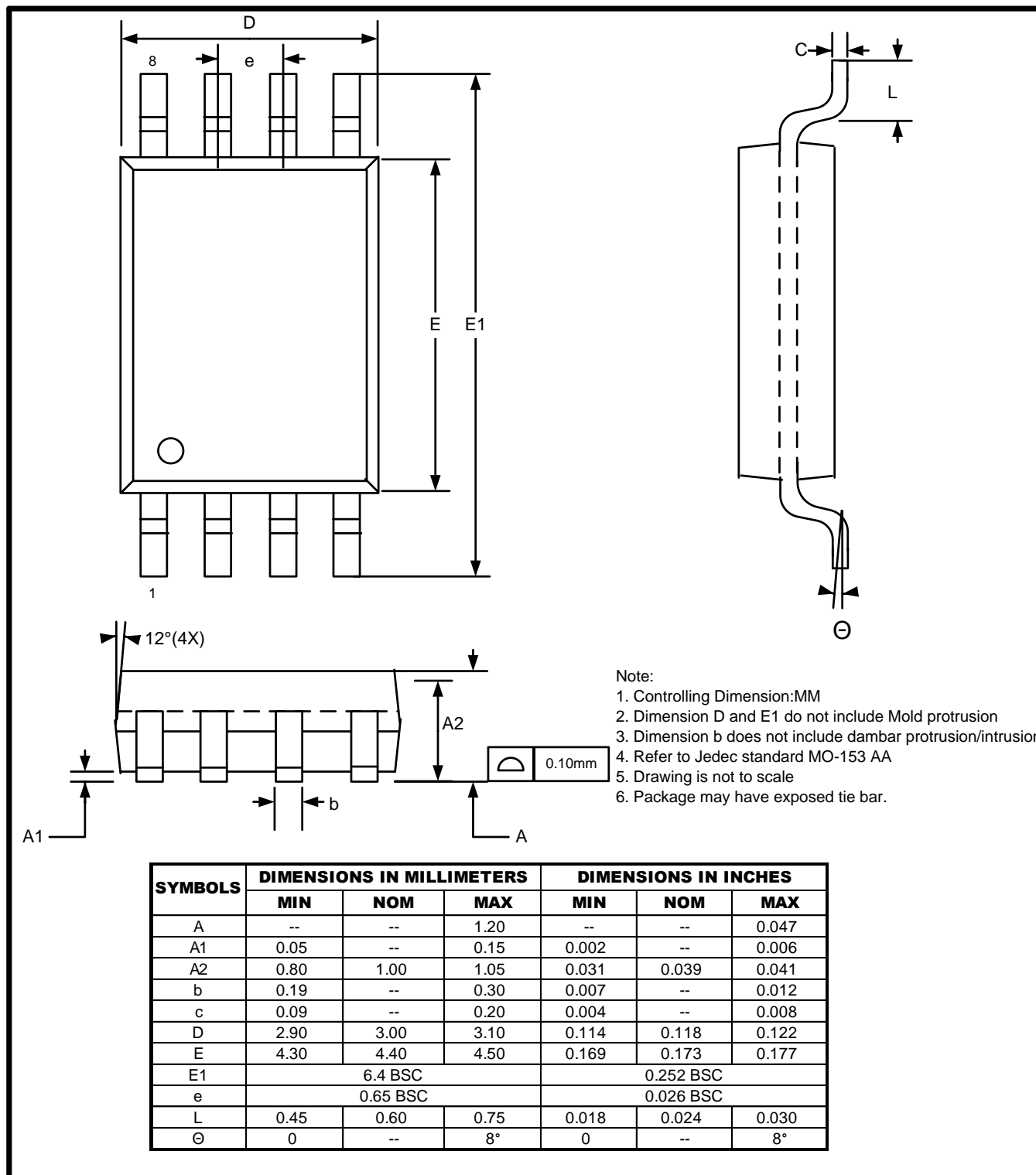



GT34C02A

9.3 SOIC/SOP

8L 150mil SOP Package Outline

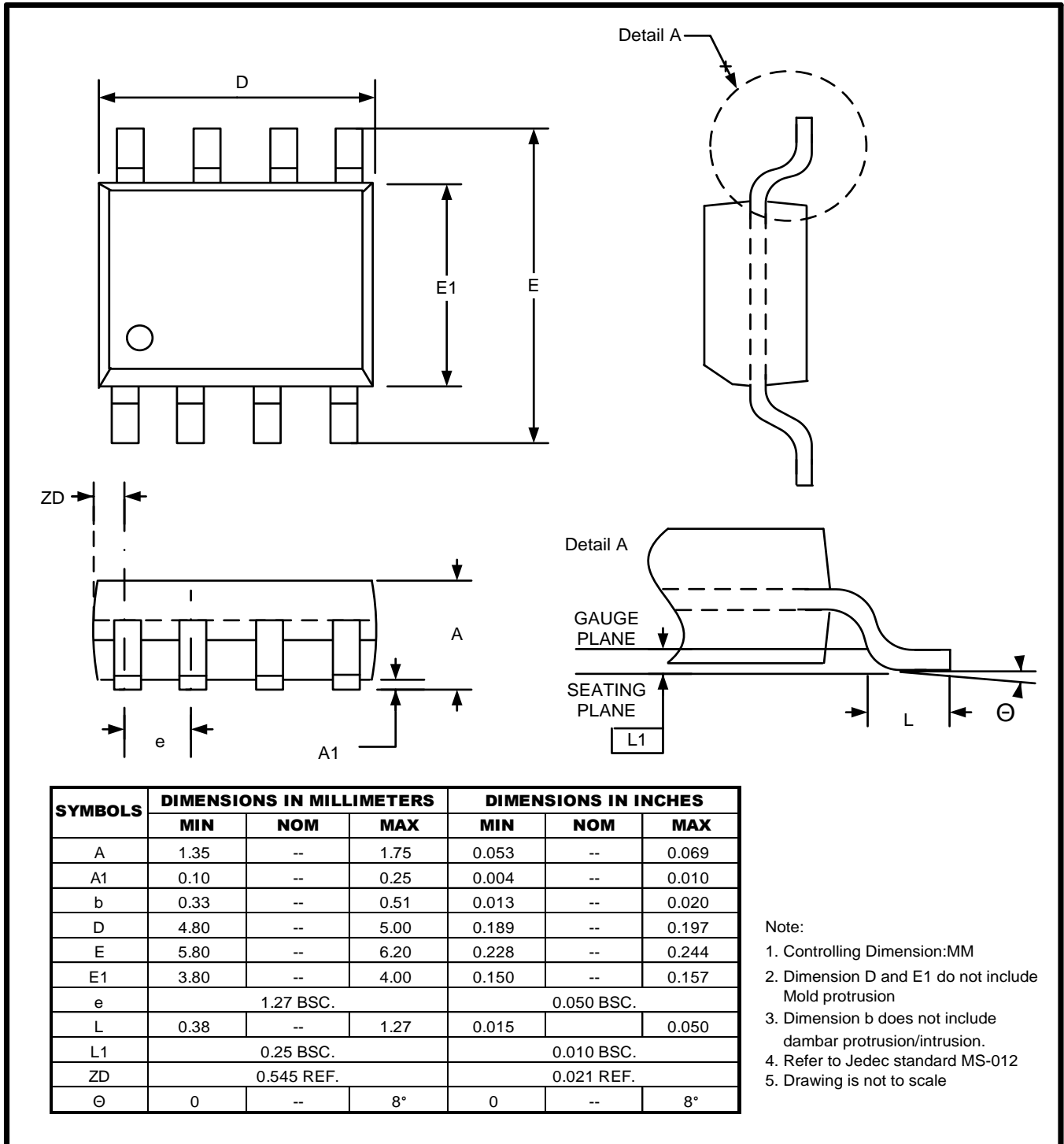



GT34C02A

10. Revision History

Revision	Date	Descriptions
A0	Dec. 2010	Initial version
A1	Jun. 2011	New datasheet format